



Food Waste Disposers InSinkErator Complete™

Submittal Sheet

- We Come To You® 5-Year In-Home Limited Warranty
- SoundSeal® technology delivers quieter performance.
- MultiGrind® technology delivers 2 stages of grind vs. 1 stage in standard disposer
- Quick Lock® mounting for fast, easy installation
- Stainless steel grinding components and grind chamber
- Stainless steel sink flange and stopper
- Overload protector manual reset
- Permanently lubricated upper and lower bearings
- Includes Quiet Collar® sound reducing sink baffle
- Includes power cord, connectors
- Includes rubber sink flange gasket
- Dishwasher drain connection
- Exclusive self-service wrench

Specifications

Type of Feed	Continuous
On/Off Control	Wall Switch
Motor	Single Phase
HP	3/4
Volts	120
HZ	60
RPM	1725
Amp. (Avg. Load)	9.5
Time Rating	Intermittent
Lubrication	Permanently Lubricated Upper & Lower Bearings
Shipping Weight (Approx.)	19 lbs. 10 oz.
Unit Finish	Black Enamel / Dark Gray
Overall Height	13-3/4"
SoundSeal Technology	Anti-Vibration Mount® Anti-Vibration Tailpipe Mount™ Quiet Collar® Sink Baffle SoundLimiter® Insulation
MultiGrind Technology	GrindShear Ring®
Grind Chamber Capacity	40 oz.
Motor Protection	Manual Reset Overload
Average Water Usage	Approx. 1 Gallon per Person Per Day
Average Electrical Usage	3-4 KWh per Year
Drain Connection	1-1/2" Anti-Vibration (Hose Clamp)
Dishwasher Drain Connection	Yes



Dimensions

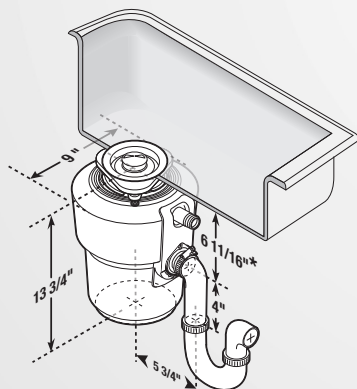

* Distance from bottom of sink to center line of disposer outlet.
Add 1/2" when stainless steel sinks are used.
** Length of tailpipe from center line of disposer outlet to end of tailpipe.
NOTE: Plumb waste line to prevent standing water in disposer motor housing.

Sample Specification

Food Waste Disposer(s) shall be InSinkErator Complete, continuous feed, with 3/4 H.P. motor, Stainless Steel Grind Chamber and Components.

Includes power cord kit and sink flange gasket.

Warranty:

5- Year parts and in-home service.

* The complete InSinkErator warranty is included in the Care & Use Booklet packed with each unit.

Job Specifications

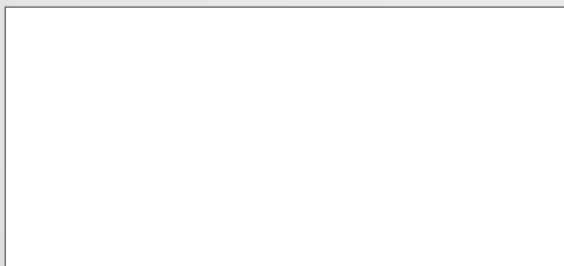

Food waste disposers can provide an environmentally responsible alternative to transporting food waste to landfills. And they can help reduce greenhouse gas emissions. At capable wastewater treatment plants, food waste can be recycled to produce renewable energy. Additionally, capable wastewater treatment plants can process food waste into fertilizer. (Check the plant in your area.)



The Emerson logo is a trademark and service mark of Emerson Electric Co. The mounting collar configuration is a trademark of Emerson Electric Co.

InSinkErator may make improvements and/or changes in the specifications at any time, in its sole discretion, without notice or obligation and further reserves the right to change or discontinue models.

1-800-558-5700
www.insinkerator.com